

# ALFRA SPLIT HOLE PUNCHER TRICUT®

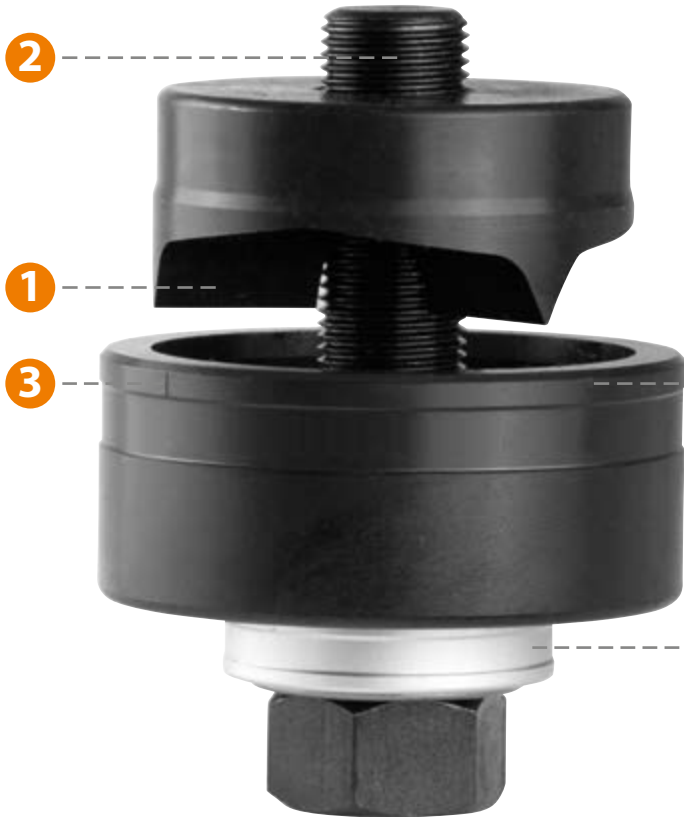

## Split hole puncher TriCut® for sheet steel (S235)

- 1 With 3-fold split
- 2 With UNF fine thread
- 3 With 4 crosshair markings for simple, central alignment



*"The max. material thickness for which a hole puncher can be used always depends on the screw and draw bolts used."*

Usable up to a material thickness of:

- 3.0 mm sheet steel with 3/4" (19.0 mm) screw or draw bolt
- 2.0 mm sheet steel with 3/8" (9.5 mm) screw or draw bolt
- 1.5 mm steel sheet with M6 (6.0 mm) screw or draw bolt

## Split hole puncher TriCut® - sets



All sets are supplied in heavy-duty practical plastic cases.

Ø mm	12.5	15.2	16.2	18.6	19.0	20.4	22.5	25.4	28.3	30.5	31.7	32.5	34.6	37.0	38.0	40.5	43.2	47.0	49.6	50.5	54.0	60.0	61.5	63.5		
Ø metric	M12	-	M 16	-	-	M 20	-	M 25	-	-	-	M 32	-	-	-	M 40	-	-	-	M 50	-	-	-	M 63		
Ø PG	7	9	-	11	-	13	16	-	21	-	-	-	-	29	-	-	-	36	-	-	42	48	-	-		
Ø Inch	1/2"	-	-	-	3/4"	-	7/8"	1"	-	1-7/32"	1-1/4"	-	-	-	1-1/2"	-	1-11/16"	-	1-15/16"	-	2-1/8"	-	2-3/8"	2-1/2"		
	0.5	0.598	0.638	0.732	0.748	0.803	0.886	1.0	1.114	1.201	1.248	1.280	1.362	1.457	1.496	1.594	1.701	1.850	1.953	1.988	2.126	2.362	2.421	2.5		
Ø Conduit	-	-	-	-	-	-	1/2"	-	3/4"	-	-	-	1"	-	-	-	1 1/4"	-	1 1/2"	-	-	-	2"	-		
Prod.-No.																										
01762			•			•		•				•				•										
01757			•			•		•				•				•				•				•		
01754	•		•			•		•				•				•										
+ 1 ball bearing screw Ø 6.0 x 40.0 mm, 1 ball bearing screw Ø 9.5 x 50.0 mm, 1 ball bearing screw Ø 19.0 x 75.0 mm, 1 pre-drill HSS Ø 10.0 mm, 1 can lubricating paste																										
01755			•			•		•				•				•				•				•		
+ 2 ball bearing screws Ø 9.5 x 50.0 mm, 1 ball bearing screw Ø 19.0 x 55.0 mm, 1 ball bearing screw Ø 19.0 x 75.0 mm, 1 pre-drill HSS Ø 10.0 mm, 1 can lubricating paste																										
01750		•		•		•		•		•		•				•										
+ 2 ball bearing screws Ø 9.5 x 50.0 mm, 1 pre-drill HSS Ø 10.0 mm, 1 tube lubricating paste																										
01751		•		•		•		•		•		•			•				•			•	•			
+ 2 ball bearing screws Ø 9.5 x 50.0 mm, 1 ball bearing screw Ø 19.0 x 55.0 mm, 1 ball bearing screw Ø 19.0 x 75.0 mm, 1 pre-drill HSS Ø 10.0 mm, 1 can lubricating paste																										

# ALFRA SPLIT HOLE PUNCHER TRICUT®

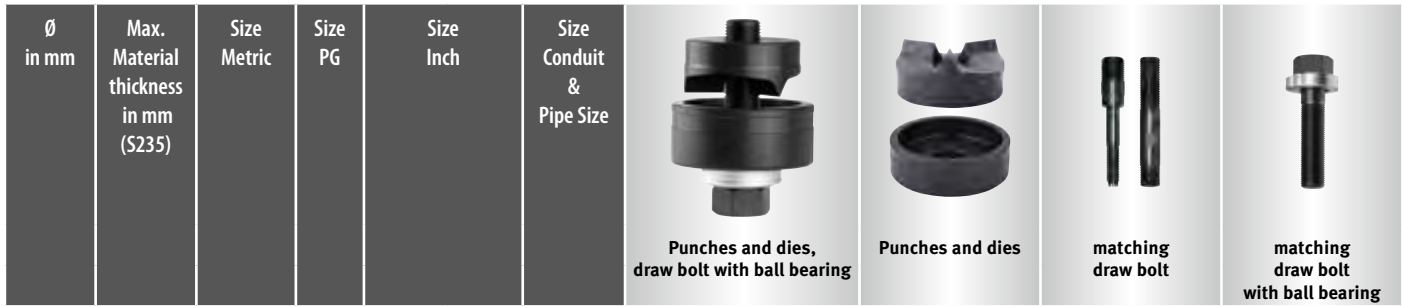

## Split hole puncher TriCut® – for sheet steel (S235)

							Prod.-No.			
12.5	1.5	M 12	7	1/2"	0.500	-	01674	01770	02022	01334
15.2	2.0	-	9	-	0.598	-	01680	01771	02003	01339
16.2	2.0	M 16	-	-	0.638	-	01683	01772		
18.6	2.0	-	11	-	0.732	-	01686	01773		
20.4	2.0	M 20	13	-	0.803	-	01689	01774		
22.5	2.0	-	16	7/8"	0.886	1/2"	01692	01775		
25.4	2.0	M 25	-	1"	1.000	-	01695	01776		
28.3	2.0	-	21	-	1.114	3/4"	01698	01777		
28.3	3.0	-	21	-	1.114	3/4"	01701	01778	02002	01340
30.5	2.0	-	-	1-7/32"	1.201	-	01703	01779	02003	01339
32.5	3.0	M 32	-	-	1.280	-	01708	01780	02002	01340
34.6	3.0	-	-	1-11/32"	1.362	1"	01711	01788		
37.0	3.0	-	29	-	1.457	-	01713	01781		
40.5	3.0	M 40	-	-	1.594	-	01715	01782		
43.2	3.0	-	-	1-11/16"	1.701	1 1/4"	01718	01789		
47.0	3.0	-	36	-	1.850	-	01720	01783		
49.6	3.0	-	-	1-15/16"	1.953	1 1/2"	01723	01790		
50.5	3.0	M 50	-	-	1.988	-	01736	01784		
54.0	3.0	-	42	2-1/8"	2.126	-	01727	01785		
60.0	3.0	-	48	-	2.362	-	01729	01786		
61.5	3.0	-	-	2-3/8"	2.421	2"	01732	01791		
63.5	3.0	M 63	-	2-1/2"	2.500	-	01739	01787		01341