

Schnittstellenwandler MICROKON

Interface converter
 Convertisseur d'interface
 Convertidor de interface
 Convertitore di interfaccia
 Conversor de interfaces



Betriebsanleitung Instructivo	Operating Instructions Istruzioni operative	Instructions de service Instruções de Serviço
--	--	--

Vor der Installation, dem Betrieb oder der Wartung des Gerätes muss diese Anleitung gelesen und verstanden werden.
 Read and understand these instructions before installing, operating, or maintaining the equipment.
 Ne pas installer, utiliser ou entretenir cet équipement avant d'avoir lu et assimilé ce instructions.
 Leer y comprender este instructivo antes de la instalación, operación o mantenimiento del equipo.
 Leggere con attenzione questi istruzioni prima di installare, utilizzare o eseguire manutenzione su questa apparecchiatura.
 Ler e compreender este manual antes da instalação, operação ou manutenção do equipamento.

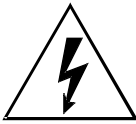
	⚠️ WARNUNG Gefährliche elektrische Spannung! Kann zu elektrischem Schlag und Verbrennungen führen. Vor Beginn der Arbeiten Anlage und Gerät spannungsfrei schalten.	⚠️ WARNING HAZARDOUS VOLTAGE. Can cause electrical shock and burns. Disconnect power before proceeding with any work in this equipment.	⚠️ ATTENTION Tension dangereuse! Risque d'électroncution et de brûlure. Isoler cet appareil du réseau avant d'y intervenir pour travaux.
	⚠️ ADVERTENCIA Tensión peligrosa! Puede causar choque eléctrico y quemaduras. Desconectar la alimentación antes de efectuar trabajo alguno en este equipo.	⚠️ ATTENZIONE Tensione elettrica pericolosa! Rischio di shock elettrico e ustioni. Prima di eseguire qualsiasi tipo di lavoro, assicurarsi che l'apparecchio e l'impianto siano scollegati.	⚠️ AVISO Tensão elétrica perigosa! Pode causar um choque elétrico e queimaduras. Antes de iniciar os trabalhos, desligue a tensão da unidade e do aparelho.

750... : Schraubklemme / Screw terminal / Borne à vis / Terminal de tornillo / Morsetto a vite / Terminal de parafusos

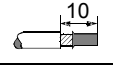
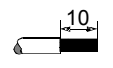
 3,0 x 0,5mm	0,4-0,5 Nm 3,5-4,5 lb•in	 10	1x (0,14-1,5)mm ² AWG 26-16
		 10	1x (0,14-2,5)mm ² AWG 26-14

751... : Federzugklemme / Spring clamp terminal / Borne à ressort / Terminal de resorte / Morsetto a molla / Terminal de molas

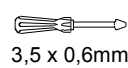
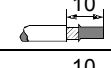
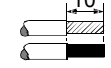
 3,5 x 0,6mm	 10	1x (0,14-1,5)mm ² AWG 26-16
	 10	1x (0,14-2,5)mm ² AWG 26-14

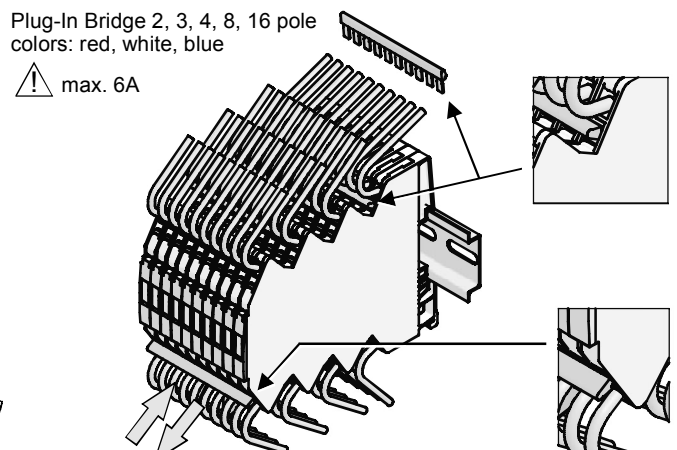
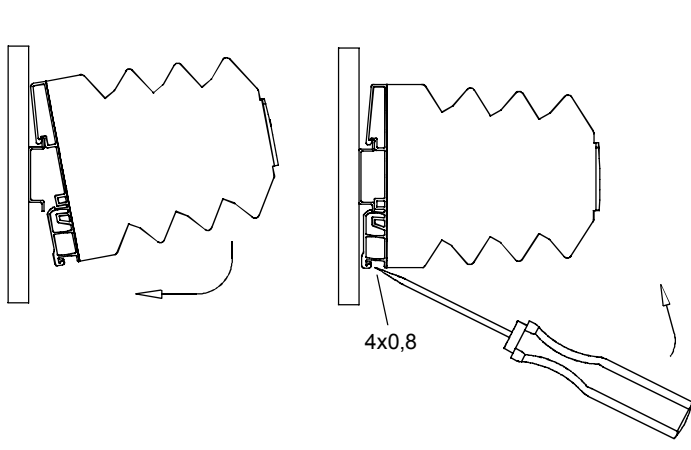
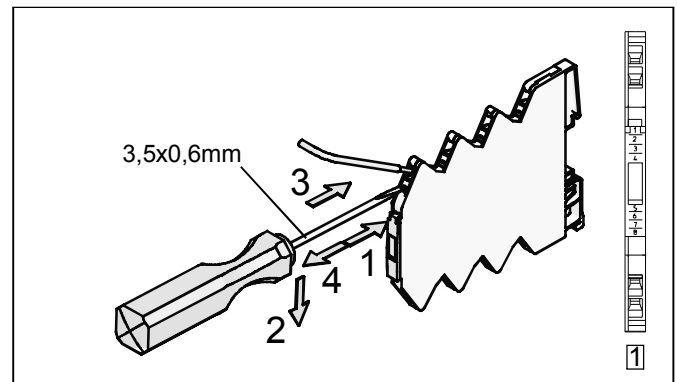
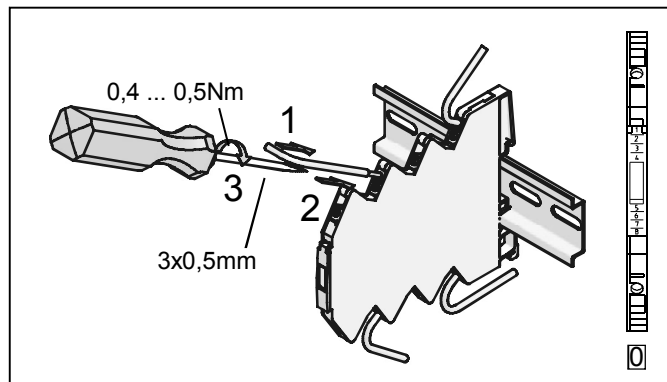

PT100

75□ 929

3 IN / 3 OUT

IN: (S1)	-50 - 200°C		
OUT: (S1)	0-10V	0-20mA	4-20mA
POWER:	DC 24V		

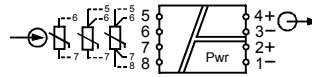

75□ 929
75□ 828

75□ 828

1 IN / 3 OUT

IN: (S1)	-150 - 50°C		
OUT: (S1)	0-10V	0-20mA	4-20mA
POWER:	DC 24V		

● → Switch On		S1					
Input	Output	1	2	3	4	5	6
-50 - 150 °C	0-10 V						
-50 - 150 °C	0-20 mA	●					
-50 - 150 °C	4-20 mA		●				
0 - 100 °C	0-10 V		●	●			
0 - 100 °C	0-20 mA				●	●	
0 - 100 °C	4-20 mA				●	●	
0 - 200 °C	0-10 V				●	●	
0 - 200 °C	0-20 mA				●	●	
0 - 200 °C	4-20 mA				●	●	●

75□ 929, 75□ 830

PT1000

75□ 830

3 IN / 3 OUT

IN: (S1)	-50 - 200°C		
OUT: (S1)	0-10V	0-20mA	4-20mA
POWER:	DC 24V		

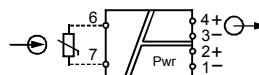

75□ 830

● → Switch On		S1					
Input	Output	1	2	3	4	5	6
-150 - 50 °C	0-10 V						
-150 - 50 °C	0-20 mA		●				
-150 - 50 °C	4-20 mA			●			

75□ 828

● → Switch On		S2			
Input configuration		1	2	3	4
2 wire / 2-Leiter		●		●	●
3 wire / 3-Leiter			●		
4 wire / 4-Leiter		●			

75□ 929, 75□ 828

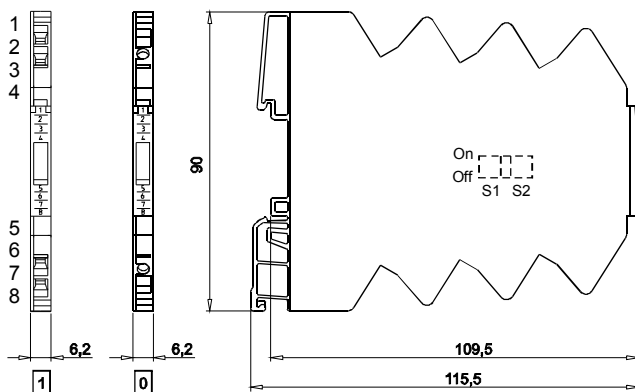

75□₀: Schraubklemme screw terminal
75□₁: Federzugklemme spring clamp terminal

Sicherheitsbestimmungen

Die Installation, Bedienung und Wartung ist von elektrotechnisch qualifiziertem Fachpersonal durchzuführen. Halten Sie die für das Errichten und Betreiben geltenden Sicherheitsvorschriften (auch nationale Sicherheitsvorschriften), Unfallverhütungsvorschriften sowie die allgemeinen Regeln der Technik ein. Die ESD-Vorschriften sind einzuhalten. Eine sichere Gerätefunktion ist nur mit zertifizierten Komponenten gewährleistet. Weitergehende Informationen siehe Datenblatt. Maximale Umgebungstemperatur: 60°C. Eine UL-zugelassene 3A-Sicherung muss dem Gerät vorgeschaltet sein.

Safety regulations

Installation, operation and maintenance may only be carried out by qualified electro-technical personnel. Please comply with the valid safety regulations (including national safety regulations), and the general rules and regulations pertaining to technology. The ESD regulations are to be kept. Reliable functioning of the equipment is only ensured with certified components. For further information see datasheet. Maximum surrounding temperature: 60°C. A 3A R/C fuse has to be connected in series to the device.

Dispositions de sécurité

L'installation, la commande et la maintenance doivent être effectuées par des techniciens électrotechniques qualifiés. Respectez les directives de sécurité (également les directives nationales de sécurité) en vigueur pour le montage et l'exploitation, les prescriptions de prévention des accidents ainsi que les règles générales de la technique. Les prescriptions relatives aux décharges électrostatiques (ESD) doivent être respectées. Le fonctionnement sûr de l'appareil n'est garanti qu'avec des composants certifiés. Pour de plus amples informations, voir la fiche technique. Température ambiante maximale: 60°C. Un fusible 3A homologué UL doit être monté en amont de l'appareil.

Technical Support: Tel. 00 49 / (0) 71 51 / 60 53 - 0 Fax 00 49 / (0) 71 51 / 60 53 - 277
email: info@luetze.de http://www.luetze.com (-288)



Technische Änderungen vorbehalten. Zum späteren Gebrauch aufbewahren!
Subject to change without prior notice. Store for use at a later date!
December 2011 Rev 01

Bestell-Nr. / Order No.: 919522.0000_01
Printed in the Federal Republic of Germany

© Friedrich Lütze GmbH & Co. KG