

Relay module with positive-action contacts



Identification	Type	LRZK 6F-D024-240H-01
	Part-No.	762089

Product version		
Hardware revision	B	
Datasheet version	03	

Use/Application/Properties		
Description	Relay module with positive-action contacts as per IEC 61810-3 (Type A) for safety switching circuits. Activated via DC 24 V. 2 NC contacts and 4 NO contacts 250 V / 6 A are available for switching small to medium loads.	

Input		
Rated voltage U_N	DC 24 V	
Input voltage	16.8 V – 30 V	
Voltage range	DC 16.8 V – 30 V	
Rated current (at U_N)	39 mA	
Status indication LED	Yellow LED	
Protection device Input	Free-wheeling diode Reverse diode	

Output		
Switching voltage	AC/DC 5 V – 250 V	
Switching current	AC/DC 0.005 A – 6 A	
Switching capacity	1500 VA / (50 W @ DC 24 V)	
Contact material	AgCuNi + 0.2 μ m Au	

General		
----------------	--	--

Relay module with positive-action contacts

Connection type	Push-In single-wire 0.20 – 2.5 mm ² AWG 20 – AWG 14 fine stranded 0.20 – 2.5 mm ² AWG 20 – AWG 14 Stripping length: 8 mm Screwdriver: 3.5 × 0.6 mm
Installation position	As desired
Clearance/creepage dist.	between control and load side (+A1, +A1, -A2, -A2, 13/14, 21/22 -> 31/32, 43/44, 53/54, 63/64) ≥5.5 mm (protective separation) between coil and control contacts (+A1, +A1, -A2, -A2 -> 13/14, 21/22) ≥3 mm (functional insulation)
short circuit protection	1000 A, SCPD 6 A function class gG / gL (back-up fuse)
Rated insulation voltage	AC/DC 300 V between control- and load side AC/DC 300 V between coil and control contacts
Degree of pollution	PD2
Over voltage category	OV2
Contact type	2 NC contact, 4 NO contact (positively driven IEC 61810-3, Type A)
Mechanical service life	approx. 10 × 10 ⁶ operations
Housing material	PC-ABS
Operation temperature range	-40 °C ... +70 °C (+85 °C 10 min)
Storage temperature range	-40 °C ... +85 °C
Dimensions (w × h × d)	22.5 × 79.0 × 84.0 mm
Weight	0.089 kg/piece
Form	Microcompact
Mounting	DIN rail mountable TS35 (EN 60715)
Protection class	IP20

Standards

EN 50155:2007-07: Railway applications – Rolling stock – Electronic equipment
EN 50121-3-2:2016-12: Railway applications – Electromagnetic compatibility – Part 3-2: Rolling stock – Apparatus
EN 50124-1:2017-03: Railway applications – Insulation coordination – Part 1: Basic requirements – Clearances and creepage distances for all electrical and electronic equipment
EN 61373:2010-09: Railway applications – Rolling stock equipment – Shock and vibration tests
EN 45545-2:2013+A1:2015: Railway applications – Fire protection on railway vehicles – Part 2: Requirements for fire behaviour of materials and components
HN_Isolationsprüfung:2017-03: Company internal standard – Insulation test

Failure Rate Prediction (MTBF)

Standards	Electronic components – Reliability – Reference conditions for failure rates and stress models for conversion: EN/IEC 61709 Failure Rates of Components – Expected values: SN 29500
Failure rate at +45 °C	355 fit
Failure rate at +45 °C	2820103 h
	1 fit equals one failure per 10 ⁹ component hours
	The indicated temperature is the mean component ambient temperature.

Relay module with positive-action contacts

Comments

The results are valid under following conditions:
 Automotive environment or industrial areas without extreme dust levels and harmful substances
 Continuous operation 8760 h per year

Dimensions

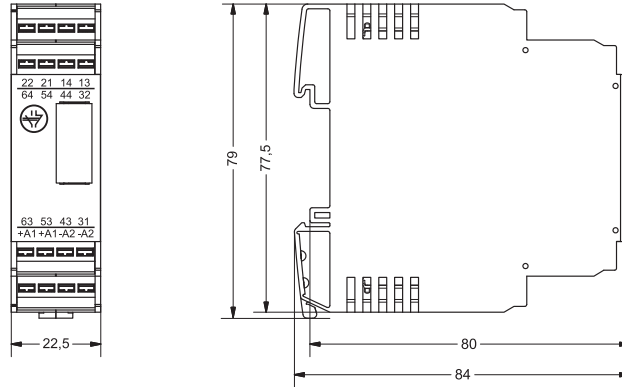

PIN assignment

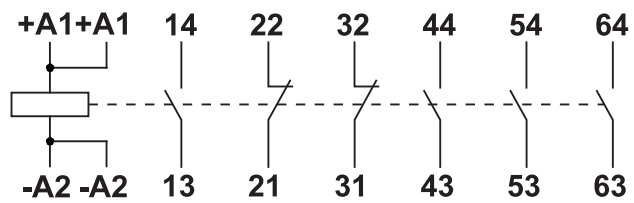

Derating

