



## S85-MH-5-Y

Distance sensor with laser emission and time of flight measurement

### INSTRUCTION MANUAL



#### CONTROLS

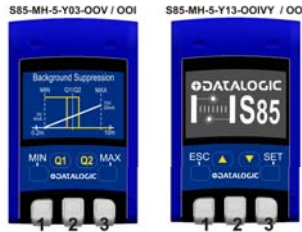

**OUTPUT LED (yellow)**  
Yellow led's 1 and 2 light on, show digital outputs Q1 e Q2 enable

**OUT OF RANGE / POWER ON LED (red/green)**  
Led 3 light on RED shows the out of range measures.  
Led 3 light on GREEN shows the sensor power on and the laser emission activations

#### INSTALLATION

The installation of the sensor can be carried out thanks to the two through holes on the body, by means of screws (eg M4x45 UNI5739) with nuts and washers.  
To install the product only and always refer to the reference surface (A) shown in Fig.1.  
There are orientable fixing brackets to ease the sensor positioning (see Accessories catalog).  
With direct fixing it has a range of angular adjustment of the laser emission of  $\pm 1.5^\circ$ . The measure is referred to the front surface of the sensor as in Fig.2.

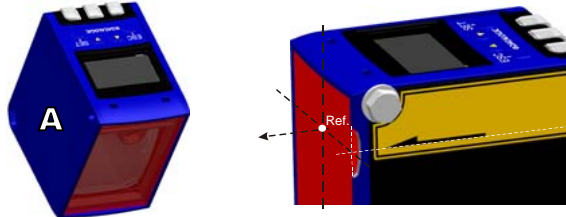

- 1) Connect and secure the M12 connector power free.
- 2) Connect the cable to power supply and/or I/O as for indicated for each model.
- 3) Fix the sensor to suitable support, taking care to align the laser spot on the center of target before.
- 4) Measure will be available within few seconds from power on.
- 5) Wait for warm up time before to start operation.
- 6) Configure device unlocking by contemporarily push of  $\blacktriangle$   $\blacktriangledown$  for S85-MH-5-Y13 (device automatically lock configuration at the end of configuration)

#### CONNECTIONS

##### S85-Y03-OOV

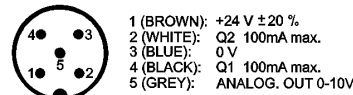

##### S85-Y13-OOIVY

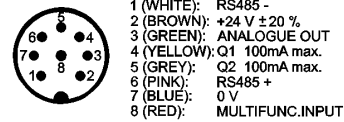

##### S85-Y03-OOI

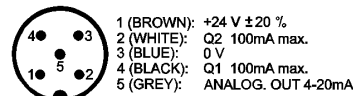

##### S85-Y13-OOY

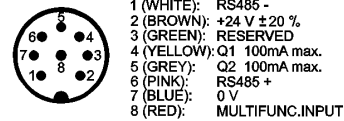

N.B.: Color of wires are referred to european standard.

#### CONFIGURATION SETTING FOR S85-MH-5-Y03

Push buttons 3sec at least and release them when dedicated LED blinks  
Push MIN to teach scalable range "min" until blinking of LED yellow 1  
Push MAX to teach scalable range "max" until blinking of LED yellow 2  
Push Q1 to teach switching point 1 until blinking of LED yellow 1  
Push Q2 to teach switching point 2 until blinking of LED yellow 2  
Push MIN + MAX to restore range default values until blinking of LED green 3  
Push MAX + Q1 / MIN + Q2 to restore default switching point 1/2 until blinking of LED green 3 (= 500 mm)

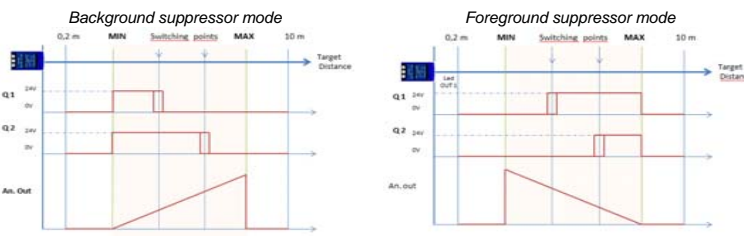

#### CONFIGURATION SETTING FOR S85-MH-5-Y13

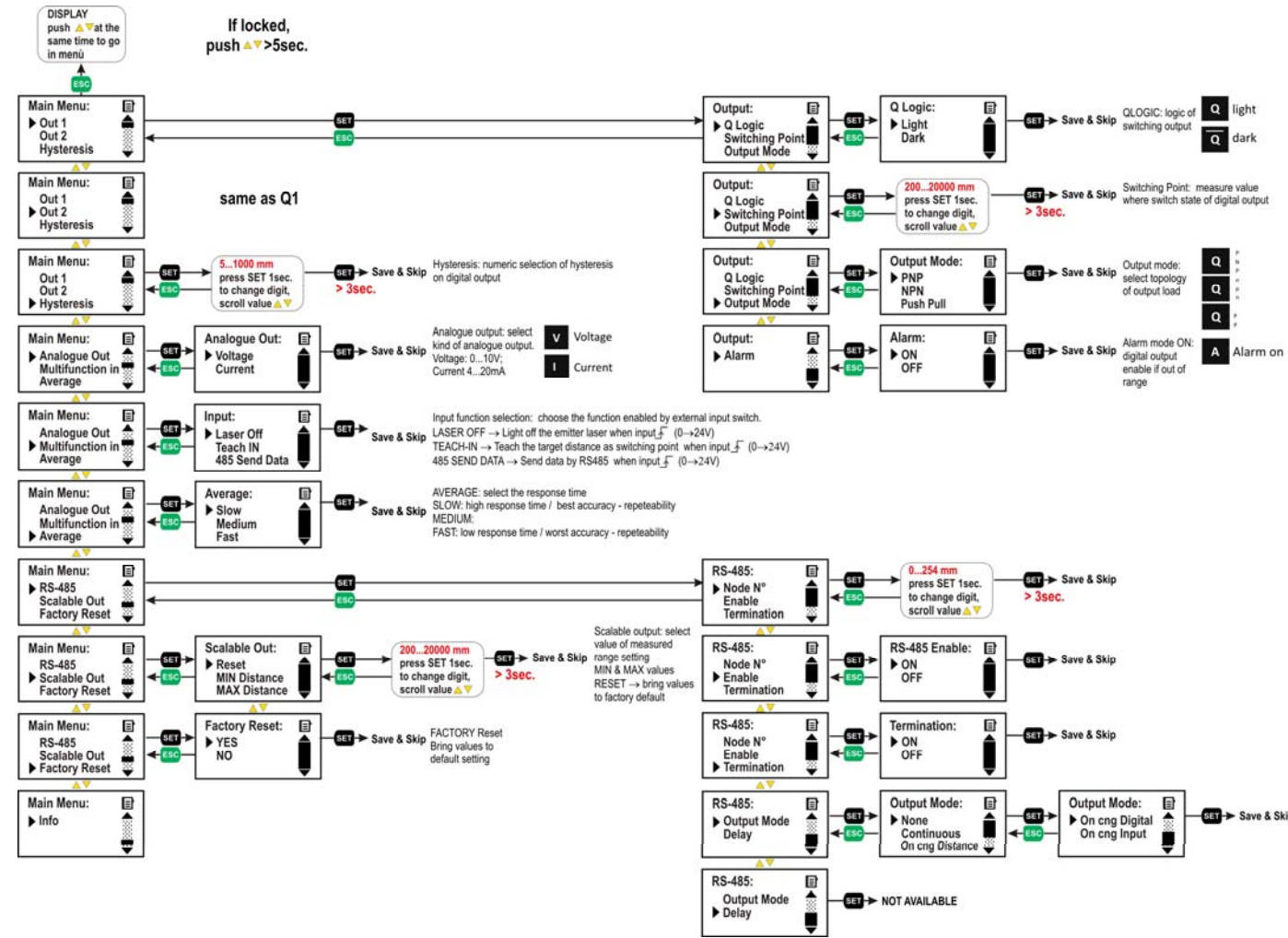

#### TECHNICAL DATA

	S85-MH-5-Y03-OOV	S85-MH-5-Y03-OOI	S85-MH-5-Y13-OOIVY	S85-MH-5-Y13-OOY
Power supply:	24 VDC $\pm 20\%$			
Consumption:	< 2.8 W		< 3 W	
Measurement range:	0.2..10 m (90% white) / 0.2..5 m (18% grey) / 0.2..3 m (6% black)		0.2..20 m (90% white) / 0.2..8 m (18% grey) / 0.2..5 m (6% black)	
Accuracy (1 sigma / 90% white XRite target):	10 mm		7 mm (slow response time)	
Repeatability (1 sigma / 90% white XRite target):	1 mm		1 mm up to 10 m / < 2 mm up to 20 m (slow response time)	
Resolution:	1 mm / 16 bit			
Hysteresis:	10mm		configurable (5 ... 1000 mm)	
Analogue output:	0-10 V scalable (1200 $\Omega$ min) short-circuit protection (Linearity error 0.6% FS)	4-20 mA scalable (100 $\Omega$ max.) short-circuit protection (Linearity error 0.2% FS)	Configurable (0-10V / 4-20 mA /scalable) short-circuit protection (Linearity error V: 0.3% FS I: 0.1% FS)	Not available
Response time SLOW :	45 msec ( typ )			
Response time MEDIUM:	30 msec ( typ )			
Response time FAST:	15 msec ( typ )			
RS 485 output:	Not available			
Switching output / Alarm:	Push Pull / Q		Configurable (PNP NPN Push Pull Q Qneg)	
Multifunction input:	not available		See par. "Default Configuration"	
Warm up time:	20 min typ			
Indicators:	Q1 (YELLOW) / Q2 (YELLOW) / POWER ON (GREEN) - OUT OF RANGE (RED) 5-digit / multi display (only for S85-MH-5-Y13-OOIVY / OOVY)			
Operating temperature:	-15 ... 50 $^\circ$ C (with powered devices) - reduce the min temp. to -5 $^\circ$ C in case of cold power on			
Storage temperature:	-25 ... 70 $^\circ$ C			
Dielectric strength:	500 VAC, 1 min between electronics and housing			
Insulating resistance:	> 20 M $\Omega$ , 500 VDC between electronics and housing			
Typical spot dimension (T = 25 $^\circ$ C)	typ 15mm @ 8m	typ 15mm @ 8m	typ 15mm @ 10m	typ 15mm @ 10m
Laser power emission / Pulse duration:	1 mW / 4 nsec			
Wavelength :	658 nm			
Laser class emission:	CLASS 2 According to IEC 60825-1 (2007)			
Ambient light rejection:	According to EN 60947-5-2, >40 Klux DC ambient light			
Vibrations:	0.5 mm amplitude, 10 ... 55 Hz frequency, for every axis (EN60068-2-6)			
Shock resistance:	11 ms (30 G) 6 shock for every axis (EN60068-2-27)			
Humidity:	< 90% not condensed			
Housing material:	ZINC ALLOY ZAMA 13 EN-1774 / Display: PC LEXAN 121R			
Lens material:	PMMA			
Mechanical protection:	IP67			
Connections:	M12 - 5 poles		M12 - 8 poles	
Dimension ( max shape):	58 x 61 x 37 mm			
Peso	250 gr.max.			
UL requirements:	Class 2 power supply according to UL 508 - Type 1 Enclosure minimum distance between the "Proximity Switch Metal Enclosure" and any "External uninsulated live part" shall be at least 12.7 mm			
CDRH requirements:	Complies with 21 CFR 1040.10 and 1040.11			

#### DEFAULT CONFIGURATION

	S85-MH-5-Y03-OOV	S85-MH-5-Y03-OOI	S85-MH-5-Y13-OOIVY	S85-MH-5-Y13-OOY
Response time (Average):	30 msec	30 msec	45 msec (Slow)	45 msec (Slow)
Analogue out:	0..10 V	4..20 mA	Disable	Disable
RS485 output mode:			Disable	Disable
RS485 termination:			Off	Off
Input function:			Teach in	Teach in
OUT1 logic:	Light	Light	Light	Light
OUT2 logic:	Light	Light	Light	Light
OUT1 mode:	Push Pull	Push Pull	Push Pull	Push Pull
OUT2 mode:	Push Pull	Push Pull	Push Pull	Push Pull
Switching point 1 (mm):	500	500	500	500
Switching point 2 (mm):	500	500	500	500
Hysteresis (mm):	10	10	10	10
Scalable range min (mm):	200	200	200	200
Scalable range max (mm):	10000	10000	20000	20000

#### DETECTION DIAGRAMS

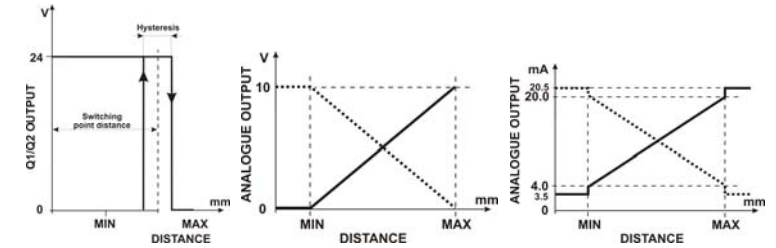

#### DIMENSIONS

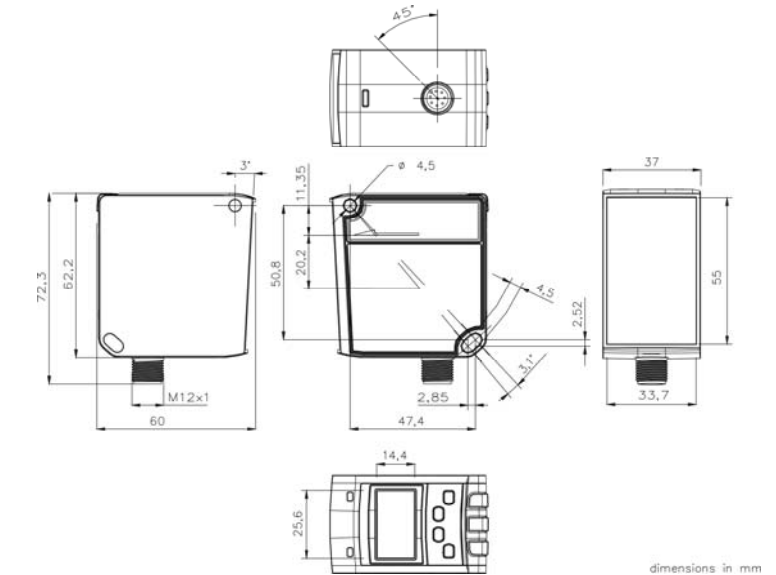

#### SAFETY WARNINGS

All the safety electrical and mechanical regulations and laws have to be respected during sensor functioning.  
The sensor has to be protected against mechanical damages.



Do not look directly into the laser beam!  
Do not point the laser beam towards people!  
Eye irradiation for over 0.25 seconds is dangerous; refer to class 2 standard (EN60825-1).  
This product is intended for indoor use only.  
Use of controls or adjustments or performance or procedures other than those specified herein may result in hazardous radiation exposure.

#### MAINTENANCE

Device do not need for particular maintenance. Anycase, take care to clean optic surface with compliant cleanser in order to avoid decay of performance . Use protection for plastic parts in case of hazardous environment .

The sensors are NOT safety devices, and so MUST NOT be used in the safety control of the machines where installed.

#### DECLARATION OF CONFORMITY

We Datalogic Automation declare under our sole responsibility that these products are conform to the 2004/108/CE and successive amendments.



#### WARRANTY

Datalogic Automation warrants its products to be free from defects.  
Datalogic Automation will repair or replace, free of charge, any product found to be defective during the warranty period of 36 months from the manufacturing date.  
This warranty does not cover damage or liability deriving from the improper application of Datalogic Automation products.

#### DATALOGIC AUTOMATION srl

Via Lavino 265 - 40050 Monte S.Pietro - Bologna - Italy  
Tel: +39 051 6765611 - Fax: +39 051 6759324 www.datalogic.com

DATALOGIC AUTOMATION cares for the environment: 100% recycled paper.  
DATALOGIC AUTOMATION reserves the right to make modifications and improvements without prior notification.

© 2013 - 2014 Datalogic Automation - ALL RIGHTS RESERVED - Protected to the fullest extent under U.S. and international laws. Copying, or altering of this document is prohibited without express written consent from Datalogic Automation, Datalogic and the Datalogic logo are registered trademarks of Datalogic S.p.A. in many countries, including the U.S.A. and the E.U.