

# Actuator LD40



LD40 is designed for industrial applications. There are two motor positions available which make it more flexible for installation in limited space. Default external reed sensors provide end of stroke indication to control unit. And additional reed sensor is optional as 'position reached' signal feedback.

## Content

<b>Features and Options</b>	3
<b>Performance Data</b>	4
<b>Dimensions</b>	6
1. Installation dimension	6
2. Drawing	6
3. Front connector	7
4. Rear connector	7
5. Motor position	7
<b>Compatibility</b>	8
<b>Cable Plug</b>	8
<b>Cable with Flying Leads</b>	9
<b>Certifications</b>	10
<b>Ordering Key</b>	11

## Features and Options

---

- Main application: Industry
- Input voltage: 12V DC / 24V DC
- Max. dynamic load: 3000N (ACME screw) / 4000N (Ball screw)
- Max. static load: 4000N (ACME screw) / 6000N (Ball screw)
- Max. speed at no load: 20.5mm/sec (Typical value)
- Stroke: 100 / 150 / 200 / 250 / 300 / 350 / 400 mm
- IP level: IP54 (Static; no-action)
- Friction clutch for over load protection <sup>(1)</sup>
- Motor position: Motor on the right hand side (Standard) / Motor on the left hand side (Option) (refer to page 7)
- External reed switch (ER): 2x ER (Standard) / 3x ER <sup>(2)</sup> (refer to page 10)
- Positioning: Optional digital positioning feedback with dual Hall effect sensors (NPN)  
(Standard right motor option only)
- Outer tube color: Anodized black
- Stainless extension tube
- Power cord length: 250 / 500 / 1000 mm
- Duty cycle: 10%, max. 2 min. continuous operation in 20 min.
- Operating ambient temperature: -25°C~+65°C
- Storage ambient temperature: -25°C~+65°C
- Certified: CE Marking, EMC Directive 2014/30/EU.

### Remarks:

- (1) The clutch can only be used as a protection device under abnormal conditions, under normal use, the clutch should not be seen to act.
- (2) External reed switch is NC-type (i.e. normal close)



## Performance Data

Model No.	Gear ratio	Spindle type	Push/Pull Max. (N)	* Typical speed (mm/s)		* Typical current (A)			
				No load	Full load	No load		Full load	
						12V	24V	12V	24V
LD40-XX-25F4B	25:1	Ball screw	4000	10.5	8.0	2.0	1.0	10.5	5.3
LD40-XX-12F4B	12.5:1	Ball screw	2000	20.5	16.3	1.9	1.0	11.3	5.6
LD40-XX-25F4A	25:1	ACME screw	3000	9.5	6.2	2.5	1.3	15.5	7.3

### Speed VS. Load

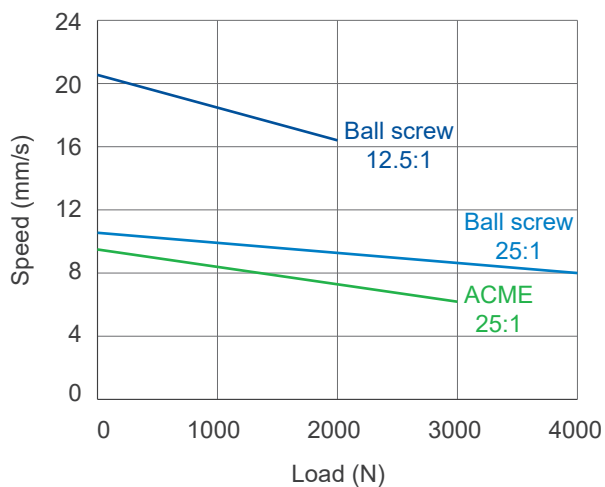

### Current VS. Load

24V DC

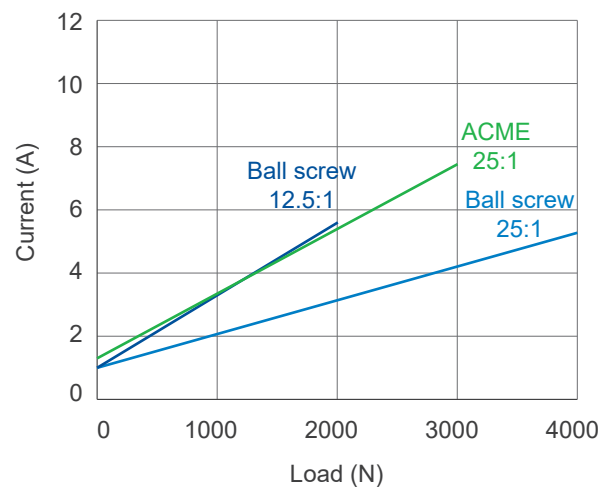

### Current VS. Load

12V DC

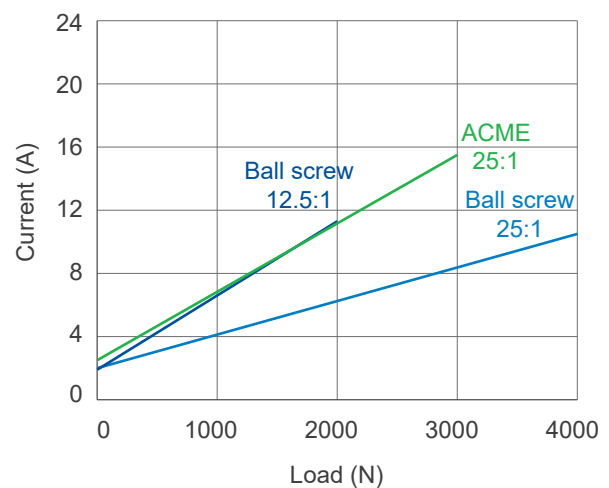

### Remarks:

- \* The typical speed or typical current means the average value neither upper limit nor lower limit, which measured under room temperature and stable power. The performance curves are made with typical values.



- Inrush current



- When the actuator starts to operate, an inrush current of about 0.2 seconds will be generated. The starting inrush current of LD40 can reach about 3 times of the typical current under the actuator load.
- If a circuit board power supply is used, the specifications must be sufficient to handle the inrush current. If batteries are used as the power source, inrush current will not be a problem.
- MOTECK controllers are designed to take into account the inrush current when the actuator starts. If the user provides his or her own controller, this feature must be considered in the specifications and protection mechanisms. Besides, the connectors, switches and relays selected by users must also be able to withstand the starting currents.



## Dimensions

### 1. Installation dimension

- Available stroke (S) = 100 / 150 / 200 / 250 / 300 / 350 / 400 mm
- Retracted length (A)  $\geq S + 153$  (Unit: mm)
- Extended length (B) = Retracted length (A) + Stroke (S)

Stroke (S)	100	150	200	250	300	350	400
Retracted length (A)	253	303	353	403	453	503	553
Extended length (B)	353	453	553	653	753	853	953

**Remarks:** The tolerance for stroke length is +0/-5mm, fully retracted length is +/-3mm.

### 2. Drawing

- Basic, without positioning feedback.

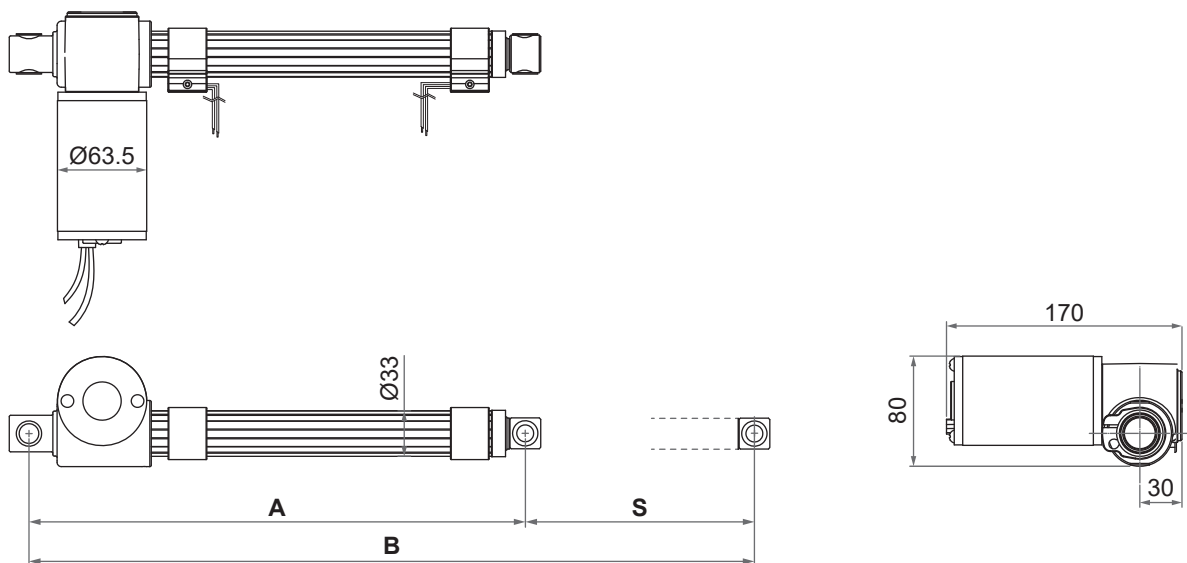

- With dual Hall effect sensors positioning feedback (additional housing attached on the motor)

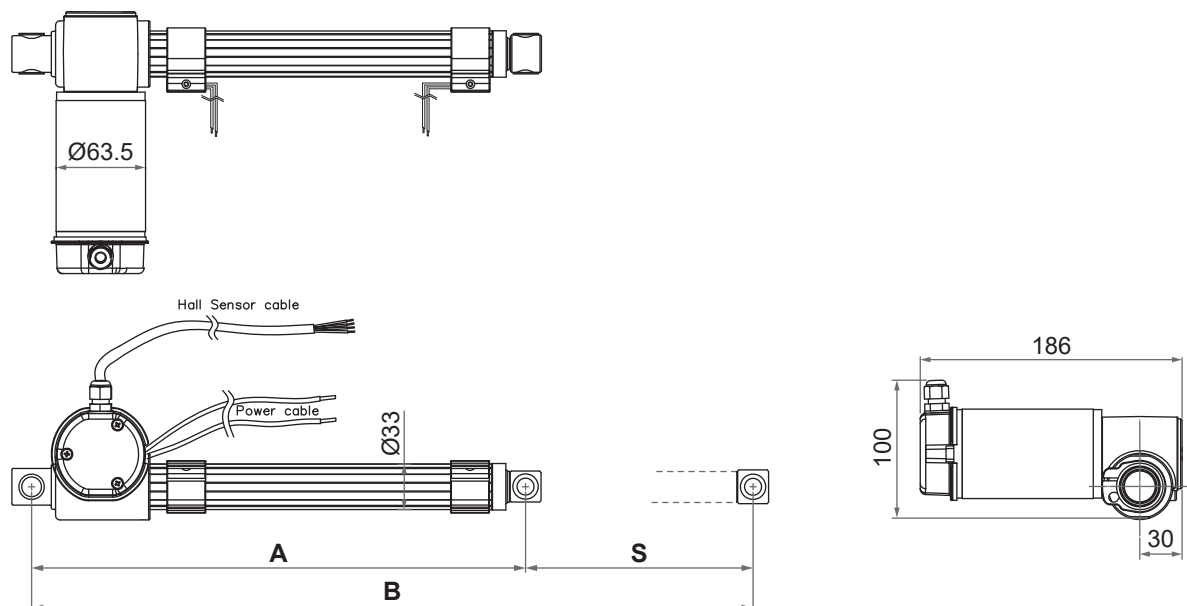

Unit: mm



### 3. Front connector

1: Metal with plastic bushing

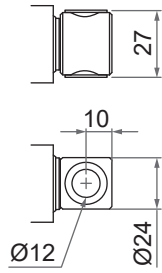

### 4. Rear connector

1: Metal with plastic bushing

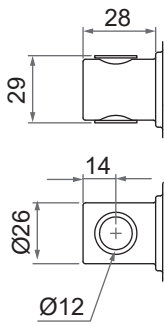

Unit: mm

### 5. Motor position

R: Motor on the right hand side (Standard)

L: Motor on the left hand side (Option)



## Compatibility

Product	Model	Application condition	LD40 spec
Control box	CI10 *		<ul style="list-style-type: none"> <li>• 24V motor</li> <li>• Without positioning sensor feedback</li> </ul>
Controller	CI72, CI73	Treat LD40 actuators as no limit switches **	<ul style="list-style-type: none"> <li>• With dual Hall effect sensors (NPN) for positioning</li> <li>• Cable with flying leads</li> </ul>
	CI74		<ul style="list-style-type: none"> <li>• With dual Hall effect sensors (NPN) for positioning</li> <li>• With minifit 6-pin plug</li> </ul>

### Remarks:

- \* CI10 could not automatically stop LD40 in response to its end of stroke signal feedback. Users must control it manually.
- \*\* The stroke limit option for the LD40 is external reed switch, so it is a signal type switch which is not supported by CI72, CI73 and CI74. Therefore, they must be set in the way that actuators have no limit switches.

## Cable Plug

### • Positioning feedback with dual Hall effect sensors

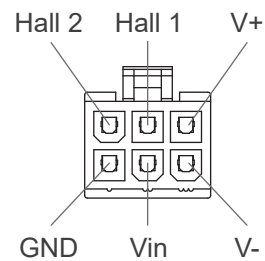

With minifit 6-pin plug



## Cable with Flying Leads

### • Basic, without positioning feedback.

	Wire color	Definition	Descriptions
Power wires	Red	DC power	Connect red wire to "Vdc +" & black wire to "Vdc -" of DC power to extend the actuator. Switch the polarity of DC input to retract it.
	Black		

### • With dual Hall effect sensors positioning feedback-NPN type

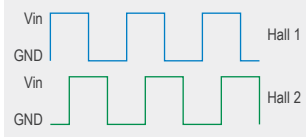
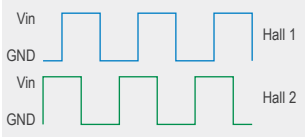
	Wire color	Definition	Descriptions								
Power wires	Red	DC power	Connect red wire to "Vdc +" & black wire to "Vdc -" of DC power to extend the actuator. Switch the polarity of DC input to retract it.								
	Black										
Signal wires	Yellow	Vin	Voltage input range (Vin): 5~20V								
	Blue	Hall 1 output	High= Input - 1.2V ( $\pm 0.6V$ ) Low= GND Hall signal data: 								
	Green	Hall 2 output	Hall effect sensor resolution: <table border="1" data-bbox="675 1055 1442 1240"> <thead> <tr> <th>Model</th> <th>Resolution (pulse/mm)</th> </tr> </thead> <tbody> <tr> <td>LD40-XX-25F4B-XXX.XXX-11-XXH4X</td> <td>25</td> </tr> <tr> <td>LD40-XX-12F4B-XXX.XXX-11-XXH4X</td> <td>12.5</td> </tr> <tr> <td>LD40-XX-25F4A-XXX.XXX-11-XXH4X</td> <td>25</td> </tr> </tbody> </table>	Model	Resolution (pulse/mm)	LD40-XX-25F4B-XXX.XXX-11-XXH4X	25	LD40-XX-12F4B-XXX.XXX-11-XXH4X	12.5	LD40-XX-25F4A-XXX.XXX-11-XXH4X	25
	Model	Resolution (pulse/mm)									
	LD40-XX-25F4B-XXX.XXX-11-XXH4X	25									
LD40-XX-12F4B-XXX.XXX-11-XXH4X	12.5										
LD40-XX-25F4A-XXX.XXX-11-XXH4X	25										
White	GND										
											



- **External reed sensors for 'end of stroke indication'**

Pick either one of wires on each sensor and connect them as common point, then the other one is defined as signal input.

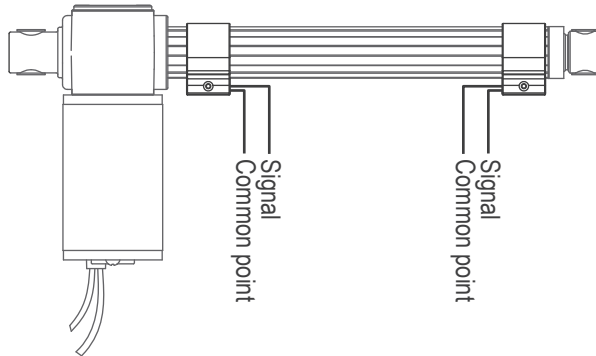

- **The 3rd reed sensor (for 'position reached' signal feedback)**

The third one must be installed in between the other two, as shown below.

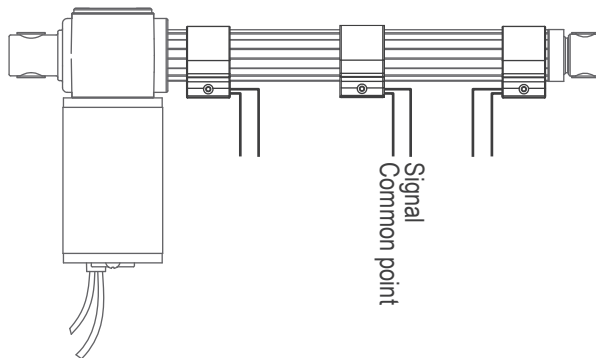

## Certifications

LD40 actuator is compliant with the following regulations, in terms of the essential conformity requirements of EMC Directive of 2014/30/EU.

Emission	Immunity
EN 61000-6-3:2007+A1:2011	EN 61000-6-1:2007 IEC 61000-4-2:2008 IEC 61000-4-3:2006+A1:2007+A2:2010 IEC 61000-4-8:2009



## Ordering Key

	LD40- 24 - 25 F 4B - 253 . 353 - 1 1 - R 2 0 4 2
<b>Input voltage</b>	12: 12V DC 24: 24V DC
<b>Gear ratio</b>	12: 12.5:1 25: 25:1
<b>Motor code</b>	F: 3900rpm
<b>Spindle type</b>	4B: Ball screw, 4mm pitch. 4A: ACME screw, 4mm pitch.
<b>Retracted length</b> (Refer to Page 6)	XXX
<b>Extended length</b> (Refer to Page 6)	XXX
<b>Front connector</b> (Refer to Page 7)	1: Metal with plastic bushing
<b>Rear connector</b> (Refer to Page 7)	1: Metal with plastic bushing
<b>Motor position</b> (Refer to Page 7)	R: Motor on the right hand side (Standard) L: Motor on the left hand side (Option)
<b>Reed sensor</b> (Refer to Page 10)	2: Reed sensor x 2 (Standard) 3: Reed sensor x 3 (Please define the 3rd reed sensor position)
<b>Positioning feedback</b>	0: None H: Dual Hall effect sensors (NPN) (Motor position R only)
<b>IP level</b>	4: IP54
<b>Cable length</b>	2: 250mm straight 5: 500mm straight A: 1000mm straight

### Terms of Use

The user is responsible for application suitability of Moteck products. As ongoing improvement process continues, products listed on the Moteck website are subject to change without prior notice. Moteck reserves the right to terminate the sales or remove any product displayed on the website, or listed in its catalogues.

