

Technical data sheet

Universal audio signal encoder



Identification

Type AST-6016.00 DC 24-110V
Part No. [826016.00](#)

Product version

Hardware revision D
Software version 4.20
Datasheet version 09

Use/Application/Properties

Description Freely-programmable audio signal encoder for rail applications to play MP3 and WAV files. The audio signal encoder has a status output for signalling the operation (max. 50 mA).

Environmental service conditions

Degree of protection IP20

Technical data

Nominal voltage range DC 14.4 V – 154 V
Rated voltage U_N DC 24–110 V
Rated current (at U_N) max. 300 mA @ 24 V / max. 65 mA @ 110 V
Frequency bandwidth 350 Hz – 5800 Hz
Sound pressure 104 dB @ 2 kHz at 1m
Volume control Configurable or infinitely adjustable via potentiometer
Technology Broadband loudspeaker
Boot-up time < 200 ms

Inputs

Number max. 6, binary-encodable, thus max. 63 messages

Lütze Transportation GmbH

Postfach 12 24 (PLZ 71366) • Bruckwiesenstraße 17-19 • D-71384 Weinstadt
Tel. +49 (0)7151 6053-545 • Fax +49 (0)7151 6053-6545
www.luetze-transportation.com • sales.transportation@luetze.de

04.10.2022 • Subject to technical modification

Part No. [826016.00](#) • Datasheet version: 09

page 1 of 4

Technical data sheet

Current Consumption	Depending on configuration 0,2 mA @ 24 V / 0,8 mA @ 110 V without input load 1.8 mA @ 24 V/2.4 mA @ 110 V with input load
Debounce time	Configurable
Switching Threshold	Configurable
Connection type input	X1: Push-In each 1×10-pin 0.20 mm ² – 2.5 mm ² AWG 24 – AWG 12 Strip length: 10 mm Screwdriver: 3.5 × 0.6 mm

Status output

Signalisation	"Device is working correct" max. 50 mA
---------------	--

General

Dimensions (w × h × d)	92.0 mm × 92.0 mm × 64.0 mm
Weight/unit	0.578 kg
Connection type	PE connection X0: Bolt M6 × 18.5
Mounting	DIN rail mounting
Status indication	LED green
Operation temperature range	-40 °C ... +70 °C (+85 °C 10 min)
Storage temperature range	-40 °C ... +80 °C

Failure Rate Prediction (MTBF)

Standards	Electronic components – Reliability – Reference conditions for failure rates and stress models for conversion: EN/IEC 61709 Failure Rates of Components – Expected values: SN 29500
Failure rate at +45 °C	1237 fit
Failure rate at +45 °C	808609 h 1 fit equals one failure per 10 ⁹ component hours The indicated temperature is the mean component ambient temperature.
Comments	The results are valid under following conditions: Automotive environment or industrial areas without extreme dust levels and harmful substances

Technical data sheet

Standards/Certifications

Standards

EN 45545-2:2013+A1:2015: Railway applications – Fire protection on railway vehicles – Part 2: Requirements for fire behaviour of materials and components
EN 50121-3-2:2016: Railway applications – Electromagnetic compatibility – Part 3-2: Rolling stock – Apparatus
EN 50155:2017: Railway applications – Rolling stock – Electronic equipment
EN 50124-1:2017: Railway applications – Insulation coordination – Part 1: Basic requirements – Clearances and creepage distances for all electrical and electronic equipment
EN 61373:1999: Railway applications – Rolling stock equipment – Shock and vibration tests
EN 61373:2010: Railway applications – Rolling stock equipment – Shock and vibration tests
HN_Isolationsprüfung:2017: Company internal standard – Insulation test

Equipment/Spare parts

Accessories

Programmer part number 826900
"AudioConfig Tool" from version 2.2.0

Software recommendations:

- Audacity – Open source programm, audacity.sourceforge.net
- From Text to Speech – Free online text–speech service, www.fromtexttospeech.com

In addition, mounting brackets are available for direct rear wall mounting under part number 826902.

Notes and Comments

Comments

The supply voltage (1/2) and the digital inputs (3-8) must have the same earth/ground (GND).

Dimensions

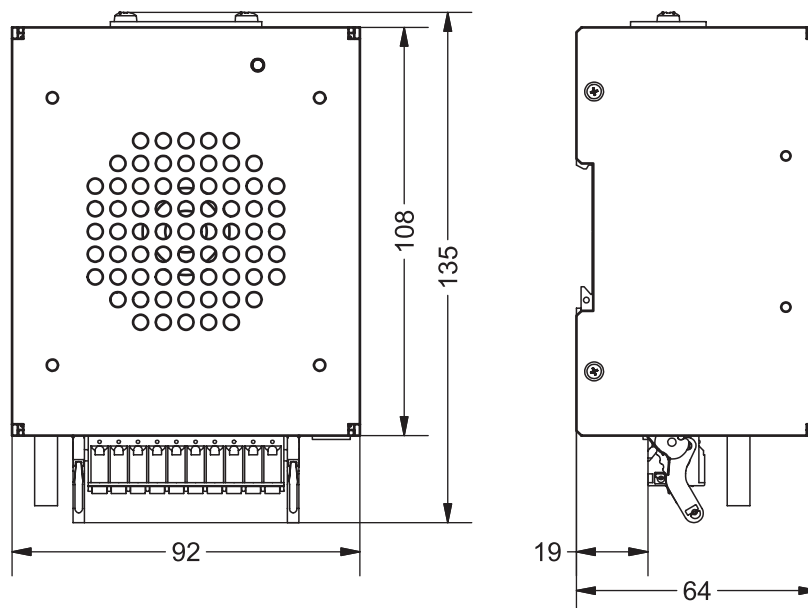

Connection assignment

Pin	Function
1	Vdd (24 V – 110 V)
2	Vss (0 V)
3	Input 1 (I1)
4	Input 2 (I2)
5	Input 3 (I3)
6	Input 4 (I4)
7	Input 5 (I5)
8	Input 6 (I6)
9	Status (S)
10	N.C.

Volume

