

## Technical data sheet

---

### Analog Limit Switch



---

#### Identification

---

Type LCON ALS FDT 806211-01  
Part No. [751922](#)

---

#### Product version

---

Datasheet version 03

---

#### Use/Application/Properties

---

Description The analog limit switch LCON ALS is used to control voltages and currents. Via an USB adaptor the switching thresholds of the two solid state relay outputs can be parameterized by software (FDT/DTM).

---

#### Input

---

Measurement input +30/-30 V, +50/-50 mA, DC +5 A/-5 A  
Parameterisation adjustable via software FDT/DTM, connection via micro USB  
Delay ON/OFF 2 ms–350 ms (adjustable by means of filter stage 1-5, default: filter stage 4 = 80 ms)  
Galvanic isolation I/O 2-way isolation  
Input resistance >800 k $\Omega$  @ +30/-30 V, 30  $\Omega$  @ +50/-50 mA, 10 m $\Omega$  @ DC +5 A/-5 A  
Zero /Span freely adjustable

---

#### Output

---

Contact type K1, K2 semiconductor NO contact  
Max. switching voltage DC 30 V  
Max. switching current DC 100 mA  
Operating mode Limit value, window, alarm output / additionally adjustable: Hysteresis, input / output delay

---

#### General

---

Dimensions (w × h × d) 6.2 mm × 90.0 mm × 115.5 mm  
Weight/unit 0.05 kg

---

#### Lütze Transportation GmbH

Postfach 12 24 (PLZ 71366) • Bruckwiesenstraße 17-19 • D-71384 Weinstadt  
Tel. +49 (0)7151 6053-545 • Fax +49 (0)7151 6053-6545  
[www.luetze-transportation.com](http://www.luetze-transportation.com) • [sales.transportation@luetze.de](mailto:sales.transportation@luetze.de)

29.09.2022 • Subject to technical modification

Part No. [751922](#) • Datasheet version: 03

page 1 of 4

## Technical data sheet

---

Housing material	PA
Mounting	DIN rail mountable TS35 (EN 60715)
Installation position	As desired

---

### Electrical isolation

---

Isolating voltage	AC 2500 V between A and B
-------------------	---------------------------

---

### Technical data

---

Rated voltage $U_N$	DC 24 V
Operation voltage range	16.8–30 V
Rated current	12 mA
Status indication LED	LED green, yellow (K1, K2), red (error)
Input/output protection	Overvoltage DC 30 V
Resolution	16-bit
Linearity error	$\pm 0.05$ % FSR
Configuration	Software: FDT / DTM
Temperature error	<100 ppm FSR
Data storage	Flash
Insulation voltage input / output	2.5 kV <sub>eff</sub>
Connection type	Spring terminal: 0.14 – 2.5 mm <sup>2</sup> Stripping length: 10 mm Screwdriver: 3.5 × 0.6 mm
Operation temperature range	-40 °C ... +70 °C
Storage temperature range	-40 °C ... +85 °C
PU (units)	1

---

### Environmental service conditions

---

<b>Altitude</b>	2000 m
Operating temperature class	OT4: -40 °C ... +70 °C
Switch-on extended Operating temperature class	not applicable
Temperature variation class	H1: no requirements
Shock/Vibration	not applicable
Class of supply voltage interruption	S1
Supply change-over class	C1: 100 ms
Useful life class	L4: 20 years
Degree of pollution	PD2
Over voltage category	OV2
Socket and edge connector	K2: Sockets for ICs and/or edge connectors are not used
Protective coating class	PC2: lacquered on both sides
Degree of protection	IP20

---

## Technical data sheet

---

### Failure Rate Prediction (MTBF)

---

Standards	Electronic components – Reliability – Reference conditions for failure rates and stress models for conversion: EN/IEC 61709 Failure Rates of Components – Expected values: SN 29500
Failure rate at -40 °C	121 fit
Failure rate at +40 °C	346 fit
Failure rate at +70 °C	1128 fit
	1 fit equals one failure per 10 <sup>9</sup> component hours
	The indicated temperature is the mean component ambient temperature.
Comments	The results are valid under following conditions: Automotive environment or industrial areas without extreme dust levels and harmful substances

---

### Standards/Certifications

---

Standards	<b>EN 50155:2007:</b> Railway applications – Rolling stock – Electronic equipment <b>EN 50155:2017:</b> Railway applications – Rolling stock – Electronic equipment – only testing according to chapter 13.3 Withstand voltage test: routine test with 1 s test duration <b>EN 50121-3-2:2016:</b> Railway applications – Electromagnetic compatibility – Part 3-2: Rolling stock – Apparatus <b>EN 50124-1:2017:</b> Railway applications – Insulation coordination – Part 1: Basic requirements – Clearances and creepage distances for all electrical and electronic equipment <b>EN 61373:1999:</b> Railway applications – Rolling stock equipment – Shock and vibration tests <b>EN 61373:2010:</b> Railway applications – Rolling stock equipment – Shock and vibration tests <b>EN 45545-2:2013+A1:2015:</b> Railway applications – Fire protection on railway vehicles – Part 2: Requirements for fire behaviour of materials and components
-----------	---

---

### Equipment/Spare parts

---

Accessories	Jumper comb 6 A (PU 10) 2-pole: 762802 (red), 762803 (white), 762804 (blue) 3-pole: 762805 (red), 762806 (white), 762807 (blue) 4-pole: 762812 (red), 762813 (white), 762814 (blue) 8-pole: 762822 (red), 762823 (white), 762824 (blue) 16-pole: 762832 (red), 762833 (white), 762834 (blue) Label holder 4×11mm white, part number 681313, PU100 Labels for laser print 4.23×11mm (sheet with 1056 labels), part number 681034, PU 1
-------------	--

---

### Notes and Comments

---

Note	For the parameterization you need the USB service cable, LCON ZB USB, part number 815900 and the software Lütze HART-DTM and PACTware. The current versions can be found in the download area of the respective product page on the LÜTZE website.
Comments	The calculated values apply under the following conditions: operation in vehicles or in industrial areas without extreme dust contamination and pollution.

---

## Dimensions

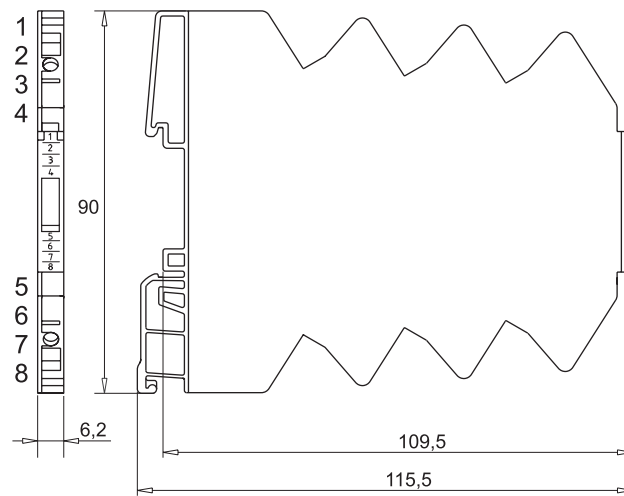

## PIN assignment

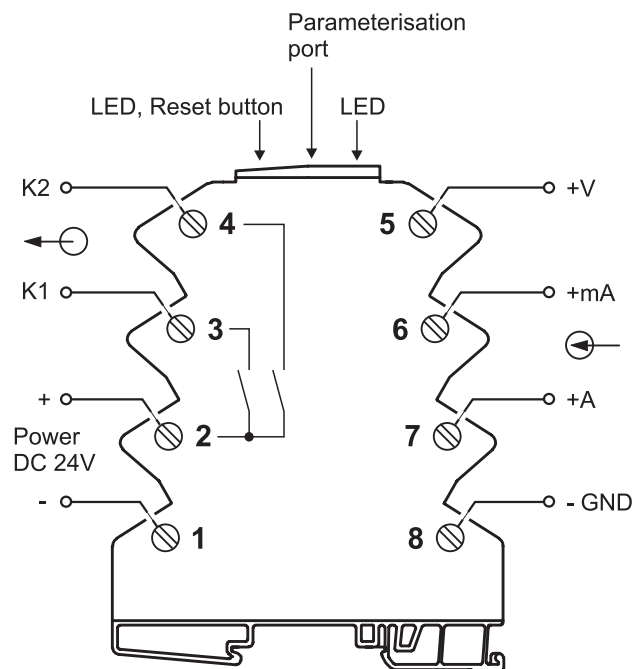

## PIN assignment

